

CHANGDE® DRYWALL SANDER

2023
PRODUCT CATALOG



PRO
POWER YOUR PERFORMANCE



**PROFESSIONAL
WALL/FLOOR TREATMENT TOOLS**



YONGKANG CHANGDE TOOLS CO.,LTD.

TEL: +86-13506792858

MOB: +86-17857958688

E-MAIL: zhengxinhua168@vip.163.com

Drywall sander / Agitator / Rough wall planer / www.changdetools.com

Drywall sander / Agitator / Rough wall planer / www.changdetools.com

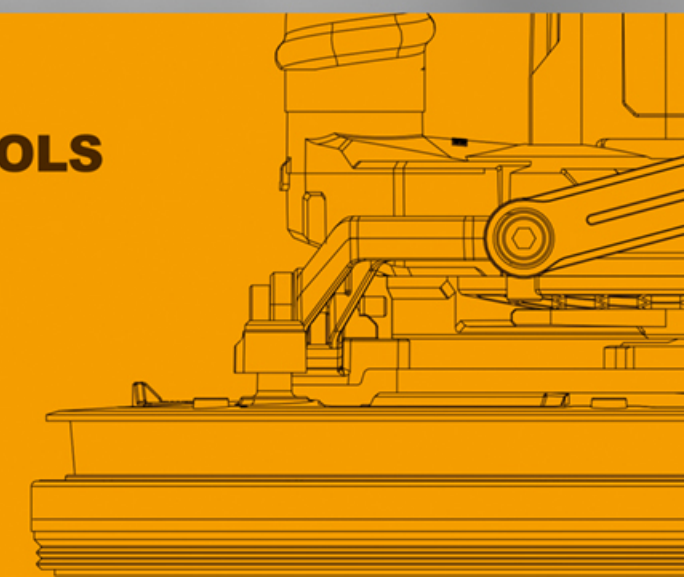

CHANGDE DRYWALL SANDER

Intertek EMC RoHS CE ETL BSCI

CHANGDE DRYWALL SANDER

**PROFESSIONAL
WALL/FLOOR TREATMENT TOOLS**

5000^{M²}

Factory occupies a wide area for 5000 square meters

18TH
2005-2023

18 years of deep cultivation in the tool industry

3^{LINES}

Have 3 automatic production workshops until 2023.

COMPANY PROFILE

TOP 500

Changde Tools located in Yongkang City, Zhejiang Province. We have been focusing on the development and manufacture of electric tools for interior decoration for ten years. Our main products are drywall sander, mixer and other household decoration tools. For now we have more than 50 employees, and the company covers an area of 5,000 square meters, with an annual production capacity of more than 300,000 sets, and output value of 50 million CNY.

Our products have passed the GS, ROHS, CE certification. Since its establishment, we have always been customer-oriented, with reliable quality and leading technology as its core competitiveness. We attach great importance and continues to increase investment in research and development so that the company has always maintained a leading position of technology in the same industry. Our products are exported to Germany, the United States, Southeast Asia, the Middle East and many other markets, and has reached comprehensive and long-term cooperation to achieve win-win results.

CHANGDE[®] DRYWALL SANDER

PROFESSIONAL
WALL/FLOOR TREATMENT TOOLS



FEATURES

- 360 degree rotation grinding disc
- 360 degree lighting
- Separate led light switch
- Durable integrated grinding disc
- Suction adjusting switch
- Detachable sanding pad cover



Self-suction power
no need vacuum cleaner

F7185B

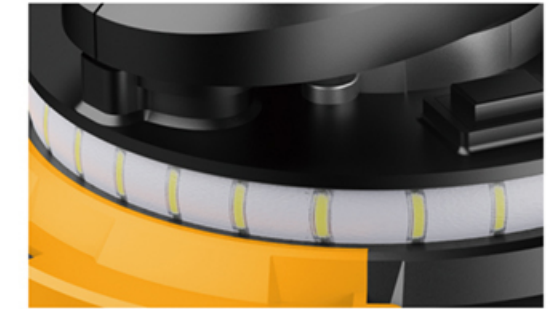

ACCESSORIES



SPECIFICATIONS

	230-240V/110-120V~50-60hz
	900W
	1400-2700RPM
	180mm
	175mm
	620x315x560mm/4pcs(Color box)
	15.5/15.05kgs(Color box)
	20GP/40GP/40HQ 1008/2128/2334pcs(Color box)



FEATURES

- 360 degree rotation grinding disc
- Variable speed lock-on switch
- Separate led light switch
- Durable integrated grinding disc
- Suction adjusting switch
- Detachable sanding pad cover



Self-suction power
no need vacuum cleaner

F7186



ACCESSORIES



SPECIFICATIONS

	230-240V/110-120V~50-60hz
	900W
	1400-2700RPM
	180mm
	175mm
	620x315x560mm/4pcs(Color box)
	15.5/15.05kgs(Color box)
	20GP/40GP/40HQ
	1008/2128/2334pcs(Color box)

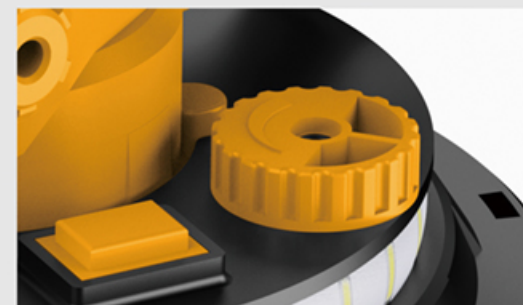

F7185



Self-suction power
no need vacuum cleaner



FEATURES

- 360 degree rotation grinding disc
- Variable speed lock-on switch
- Separate led light switch
- Durable integrated grinding disc



F7185A



Self-suction power
no need vacuum cleaner



FEATURES

- 360 degree rotation grinding disc
- Variable speed lock-on switch
- Separate led light switch
- Durable integrated grinding disc



SPECIFICATIONS

	230-240V/110-120V~50-60hz	230-240V/110-120V~50-60hz
	900W	900W
	1400-2700RPM	1400-2700RPM
	180mm	180mm
	175mm	175mm
	620x315x560mm/4pcs(Color box)	620x315x560mm/4pcs(Color box)
	15.5/15.05kgs(Color box)	15.5/15.05kgs(Color box)
	20GP/40GP/40HQ	1008/2128/2334pcs(Color box)
	1008/2128/2334pcs(Color box)	1008/2128/2334pcs(Color box)

FEATURES

- 360 degree rotation grinding disc
- 360 degree lighting
- Separate led light switch
- Durable integrated grinding disc
- Suction adjusting switch
- Detachable sanding pad cover



Self-suction power
no need vacuum cleaner

F7236C



ACCESSORIES

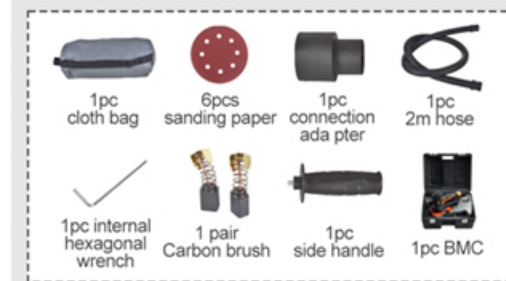

F7236A



Self-suction power
no need vacuum cleaner



FEATURES

Remove the bracket before sanding

- Separate led light switch
- Durable integrated grinding disc
- Suction adjusting switch
- Detachable sanding pad cover



F7236



Self-suction power
no need vacuum cleaner



FEATURES

- Separate led light switch
- Durable integrated grinding disc
- Suction adjusting switch
- Detachable sanding pad cover



SPECIFICATIONS

	230-240V/110-120V~50-60hz
	1280W
	1400-2600RPM
	225mm
	215mm
	620x315x580mm/4pcs(Color box)
	17.8/16.8kgs(Color box)
	20GP/40GP/40HQ
	1008/2128/2334pcs(Color box)



SPECIFICATIONS

	230-240V/110-120V~50-60hz	230-240V/110-120V~50-60hz
	1280W	1280W
	1400-2600RPM	1400-2600RPM
	225mm	225mm
	215mm	215mm
	620x315x580mm/4pcs(Color box)	620x315x580mm/4pcs(Color box)
	17.8/16.8kgs(Color box)	17.8/16.8kgs(Color box)
	20GP/40GP/40HQ	1008/2128/2334pcs(Color box)
	1008/2128/2334pcs(Color box)	1008/2128/2334pcs(Color box)



FEATURES

- Long handle 225 wall polishing machine, high brightness dual light strip
- The disc is detachable and can be chamfered internally
- 1200 watt high-power motor meets the working needs of different environments
- The machine is foldable, smaller in size, and convenient to carry
- Angu silver copper reinforced commutator
- Imported material brush
- The light strip switch is more convenient to operate on the handle
- The length of the extra long telescopic rod can reach 1.8 meters
- Reasonable sealing structure without dust leakage



Self-suction power
no need vacuum cleaner



F7258



Dry



Dust bag



Strong Suction



Multi-Function



SPECIFICATIONS

	230-240V/50hz
	1200W
	800-2200rRPM
	225mm
	215mm
	1160x320x440mm/2pcs(Color box)
	10/6kgs(Color box)
	20GP/40GP/40HQ 340/580/830pcs(Color box)



F7258



Self-suction power
no need vacuum cleaner



FEATURES



- Imported material brush
- The light strip switch is more convenient to operate on the handle
- The length of the extra long telescopic rod can reach 1.8 meters
- Reasonable sealing structure without dust leakage



F7248



Self-suction power
no need vacuum cleaner



FEATURES



- Imported material brush
- The light strip switch is more convenient to operate on the handle
- The length of the extra long telescopic rod can reach 1.8 meters
- Reasonable sealing structure without dust leakage



FEATURES

- Long handle 225 wall polishing machine, high brightness dual light strip
- The disc is detachable and can be chamfered internally
- 800 watt high-power motor meets the working needs of different environments
- The machine is foldable, smaller in size, and convenient to carry
- Angu silver copper reinforced commutator
- Imported material brush
- The light strip switch is more convenient to operate on the handle
- The length of the extra long telescopic rod can reach 1.8 meters
- Reasonable sealing structure without dust leakage



Connected
vacuum cleaner

7234B



Dry



Dust bag



Strong Suction



Multi-Function

SPECIFICATIONS

	230-240V/50hz	230-240V/50hz
	1200W	950W
	800-2200RPM	1000-2000RPM
	225mm	225mm
	215mm	215mm
	1160x320x440mm/2pcs(Color box)	1180x300x200mm/2pcs(Color box)
	10/6kgs(Color box)	5/3kgs(Color box)
	20GP/40GP/40HQ	340/580/830pcs(Color box)
		390/680/960pcs(Color box)

SPECIFICATIONS

	230-240V/110-120V~50-60Hz
	800W
	1000-2100RPM
	225mm
	215mm
	760x285x255mm/1pcs(Color box)
	6.4/3.9kgs(Color box)
	20GP/40GP/40HQ
	480/1080/1200pcs(Color box)

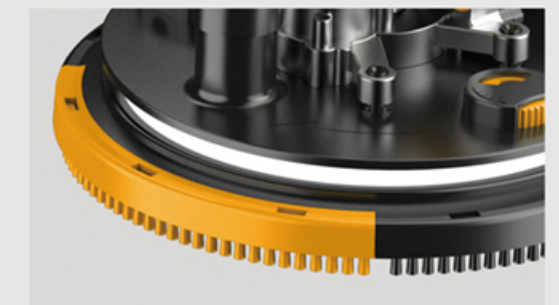

FEATURES

- Long handle 225 wall polishing machine, high brightness dual light strip
- The disc is detachable and can be chamfered internally
- 880 watt high-power motor meets the working needs of different environments
- The machine is foldable, smaller in size, and convenient to carry
- Angu silver copper reinforced commutator
- Imported material brush
- The light strip switch is more convenient to operate on the handle
- The length of the extra long telescopic rod can reach 1.9 meters
- Reasonable sealing structure without dust leakage



Self-suction power
no need vacuum cleaner

- Dry
- Dust bag
- Strong Suction
- Multi-Function



F7241-2



- 6pcs sanding paper
- 1pc 2m hose
- 1pc S5 hexagon wrench
- 1pc Backpack
- 1pair Carbon brush
- 1pc cloth bag
- 3pcs Adjusting shim



SPECIFICATIONS

	230-240V/50hz
	880W
	1000-2100RPM
	225mm
	215mm
	825x310x250mm/1pcs(Color box)
	6.8/4kgs(Color box)
	20GP/40GP/40HQ 440/750/1060pcs(Color box)



F7231



Self-suction power
no need vacuum cleaner

FEATURES

- Longer motor and machine lifetime
- With soft-start function for safe use
- No gears, the noise is much lower than traditional models
- 2 times higher working efficiency than traditional models



- 6pcs sanding paper
- 1pc 2m hose
- 1pc S5 hexagon wrench
- 1pc Backpack
- 1pair Carbon brush
- 1pc cloth bag
- 3pcs Adjusting shim

SPECIFICATIONS

	230-240V/110-120V~50-60Hz	230-240V/50hz
	880W	880W
	1000-2100RPM	1000-2100RPM
	225mm	225mm
	215mm	215mm
	825x310x250mm/1pcs(Color box)	825x310x250mm/1pcs(Color box)
	6.8/4kgs(Color box)	6.8/4kgs(Color box)
	20GP/40GP/40HQ 440/750/1060pcs(Color box)	440/750/1060pcs(Color box)

F7239



Self-suction power
no need vacuum cleaner

FEATURES

- Imported material brush
- The light strip switch is more convenient to operate on the handle
- The length of the extra long telescopic rod can reach 1.8 meters
- Reasonable sealing structure without dust leakage



F7237A



Connected vacuum cleaner



FEATURES

- Spot LED Light
- Flexible handle provides easy maneuvering while sanding
- Quickly retractable joystick
- Foldable handle design LED lighting



F7237B



Connected vacuum cleaner



FEATURES

- Double-layer LED strip light
- Flexible handle provides easy maneuvering while sanding
- Quickly retractable joystick
- Foldable handle design LED lighting

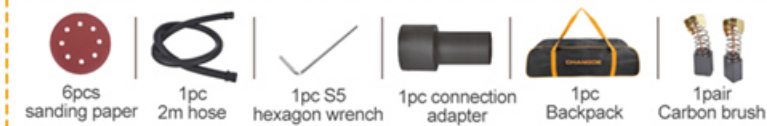

F7238A



Self-suction power no need vacuum cleaner



FEATURES

- Spot LED Light
- Flexible handle provides easy maneuvering while sanding
- Quickly retractable joystick
- Foldable handle design LED lighting



F7238B



Self-suction power no need vacuum cleaner



FEATURES

- Double-layer LED strip light
- Flexible handle provides easy maneuvering while sanding
- Quickly retractable joystick
- Foldable handle design LED lighting



SPECIFICATIONS

	230-240V/110-120V~50-60Hz	230-240V/110-120V~50-60Hz
	800W	800W
	1000-2100RPM	1000-2100RPM
	225mm	225mm
	215mm	215mm
	760x285x255mm/1pcs(Color box)	760x285x255mm/1pcs(Color box)
	6.4/3.9kgs(Color box)	6.4/3.9kgs(Color box)
	20GP/40GP/40HQ	480/1080/1200pcs(Color box)

SPECIFICATIONS

	230-240V/110-120V~50-60Hz	230-240V/110-120V~50-60Hz
	880W	880W
	1000-2100RPM	1000-2100RPM
	225mm	225mm
	215mm	215mm
	760x285x255mm/1pcs(Color box)	745x300x260mm/1pcs(Color box)
	6.7/4.1kgs(Color box)	7/4.35kgs(Color box)
	20GP/40GP/40HQ	480/1080/1200pcs(Color box)
		480/826/1170pcs(Color box)

FEATURES

- Quenched material, steel and stone plate
- Able to grind 90° wall corners without dead corners
- 6-speed adjustment for easy changes in different scenarios
- Comfortable grip, smooth polishing, and instant smoothing
- Efficient polishing, shorter working hours, and more efficient work
- All copper wire high-quality motor, high temperature resistance, strong power, and more powerful polishing



Connected vacuum cleaner



Dry



Dust bag



Strong Suction



Multi-Function

C7232



1pc socket wrench | 1pc 2m hose | 2pcs Adjusting shim

SPECIFICATIONS

	220V/50Hz
	2200W
	2200-4800RPM
	150mm
	1170x280x240mm/1pcs(Color box)
	7.5/3.4kgs(Color box)
	20GP/40GP/40HQ
	360/740/868pcs(Color box)



FEATURES

- Quenched material, steel and stone plate
- Able to grind 90° wall corners without dead corners
- 6-speed adjustment for easy changes in different scenarios
- Comfortable grip, smooth polishing, and instant smoothing
- Efficient polishing, shorter working hours, and more efficient work
- All copper wire high-quality motor, high temperature resistance, strong power, and more powerful polishing



Connected vacuum cleaner

C7150



SPECIFICATIONS

	220V
	1800W
	3000-6000r/min
	150mm
	1150x550x250mm/2pcs(BMC)
	5/4kgs(BMC)
	20GP/40GP/40HQ
	360/740/868pcs(BMC)



ACCESSORIES

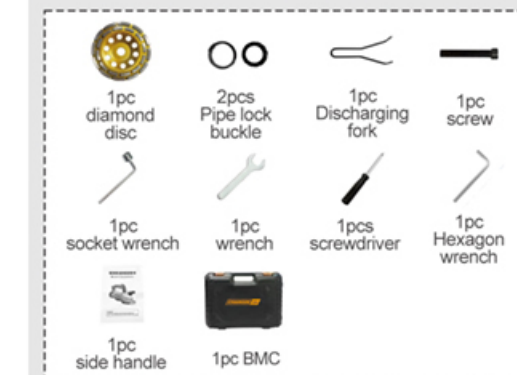

FEATURES

- Quenched material, steel and stone plate
- Able to grind 90° wall corners without dead corners
- 6-speed adjustment for easy changes in different scenarios
- Comfortable grip, smooth polishing, and instant smoothing
- Efficient polishing, shorter working hours, and more efficient work
- All copper wire high-quality motor, high temperature resistance, strong power, and more powerful polishing



Connected vacuum cleaner

C7180



ACCESSORIES

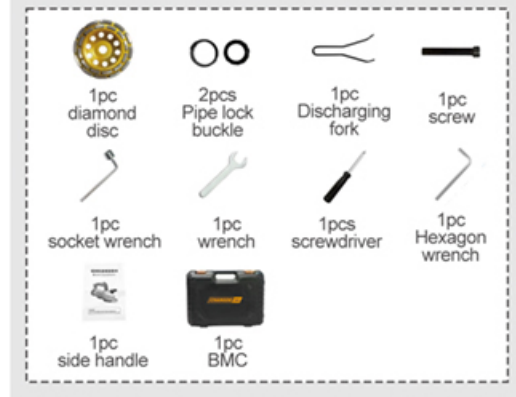

FEATURES

- High power, ultra strong wind power, fast removal of fallen leaves, simple, efficient, time-saving, and labor-saving
- Increasing copper wire for high-speed motors greatly improves work efficiency
- Large intake air volume grid wind gathering design, surging wind, easy to handle multiple scenarios
- Increase the power of the air outlet and easily blow away various types of dust, solving various problems



B6801

ELECTRIC BLOWER



Dry blowing



Portable



Strong winds



Large air volume



SPECIFICATIONS

	220V/50Hz
	1800W
	3000-6000 RPM
	180mm
	645x395x290mm/4pcs(BMC)
	5/4kgs(BMC)
	20GP/40GP/40HQ 380/650/920pcs(BMC)



SPECIFICATIONS

	230-240V/50Hz
	3800W
	I: 14800RPM II: 17600RPM
	MAX AIR SPEED I: 135KM/H II: 165KM/H
	MAX AIR VOLUME I: 680m³/h II: 850m³/h
	460x245x280mm/1pc(Color box)
	2.6/1.9kgs(Color box)
	20GP/40GP/40HQ 880/1520/2150pcs(Color box)

